

TVS 

***Scooty
pep+***

**OWNER'S
MANUAL**



SCAN FOR 24X7
ROADSIDE ASSISTANCE NOW

**WE GO THE DISTANCE
WHEN IT COMES
TO YOUR ASSISTANCE.**

MAKE YOUR RIDES HASSLE-FREE AND STRESS-FREE
WITH SERVICE BEYOND JUST ASSISTANCE.

Sign up for our 24X7 Roadside Assistance and enjoy
quick and efficient service anytime, anywhere.

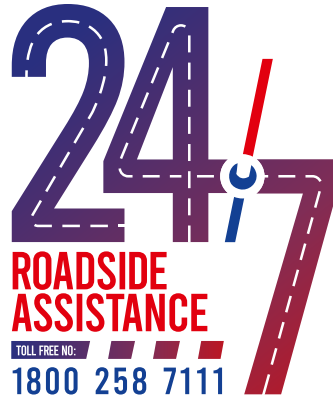



Drive In.

Drive Out.



**Say bye-bye to waiting time
for servicing your bike.**

Get your vehicle serviced in 1 hour at no additional cost. Contact your nearest Dealership for details. †

† Facility available at selected Dealerships only. Terms and conditions apply





Busy Life? Easy Servicing!

Now, service your bike anywhere, anytime.

- ★ Service the vehicle at your door step.
- ★ Available for regular maintenance or breakdown service only.
- ★ Offered at nominal convenience charges.

Contact your nearest Dealership for details.[†]

[†]Facility available at selected Dealerships only. Terms and conditions apply





Busy Life? Easy Servicing!

Now, service your bike anywhere, anytime.

- ★ Service the vehicle at your door step.
- ★ Available for regular maintenance or breakdown service only.
- ★ Offered at nominal convenience charges.

Contact your nearest Dealership for details.[†]

[†]Facility available at selected Dealerships only. Terms and conditions apply

| | |
|------------------------------------|-----|
| EXPRESS SERVICE | I |
| EXPERT ON WHEELS | II |
| PICKUP AND DROP | III |
| CONTENTS | IV |
| CONTACT(S) FOR SUPPORT | 1 |
| UNIQUE FEATURES OF TVS Scooty Pep+ | 5 |
| FOREWORD | 8 |
| NOTICE | 9 |
| SAFETY INFORMATION | 10 |
| RUNNING-IN INFORMATION | 11 |
| SAFE RIDING TIPS | 12 |
| KNOW YOUR TVS Scooty Pep+ | 16 |
| RIDING YOUR TVS Scooty Pep+ | 31 |
| MAINTENANCE | 36 |
| WARRANTY AND SERVICES | 59 |
| TECHNICAL SPECIFICATIONS | 66 |
| GENERAL INFORMATION | 71 |



Incase you need any Clarification please contact

TVS Motor Company Authorised Main Dealer / Authorised Dealer

Or

TVS Motor Company's Area Offices (flip over for addresses)

Or

Toll Free Number : 1800-258-7111

Email : customercare@tvsmotor.com

Disclaimer : TVS Motor Company or any of its officials / Authorized Main dealer / Authorized Dealer do not ask customers for bank / card / wallet details / authentication. In case you face any such claim, please report to the relevant local authorities immediately.

CONTACT AT OUR AREA OFFICES**TAMILNADU-1, 3 & 4****1. TVS Motor Company Limited**

V Floor, Gee Gee Universal,
No. 2, MC Nichols Road,
Chetpet, Chennai - 600 031.
Phone : 044-28361651/28361654
Email : AO.Chennai@tvs motor.com
AO.Madurai@tvs motor.com

TAMILNADU-2**2. TVS Motor Company Limited**

No. 10, 2nd floor,
Shree Shanmugapriya Towers,
Kannuswamy Street,
Behind Hotel Annapoorna,
R S Puram, Coimbatore - 641 002.
Phone : 0422-4350060/2541035
Email : AO.Coimbatore@tvs motor.com

KERALA**3. TVS Motor Company Limited**

Ambady Towers, Second Floor,
Door No. 27/631, A6,
Edappally-Pookkattupady Road,
Edappally PO., Cochin - 682 024.
Phone : 0484-2544578/2556938
Email : AO.Cochin@tvs motor.com

KARNATAKA-1, 2 & GOA**4. TVS Motor Company Limited**

No. 600, Anand Surya, 2nd Floor,
15th Cross, 6th Phase, JP Nagar,
Opp. BMTC Bus Stop,
Bangalore - 560 078.
Phone : 080-26653433
Email : AO.Bangalore@tvs motor.com

ANDHRAPRADESH & TELANGANA**5. TVS Motor Company Limited**

Rukumani Towers, First Floor,
No. 3-11-30, Plot No. 11,
Paigha Colony, Behind Anand Theater,
Secunderabad - 500 003.
Phone : 040-27840590/27844419
Email : AO.Hyderabad@tvs motor.com
AO.Vijayawada@tvs motor.com

MAHARASHTRA-1 & 2**6. TVS Motor Company Limited**

No. 401, 4th Floor, The Chambers,
Plot No. 4/12/3, Near Ganapati Chowk,
Viman Nagar, Pune - 411 014.
Phone : 020-26632112/26632110
Email : Service.pune@tvs motor.com

MAHARASHTRA-3 & CHATTISGARH**7. TVS Motor Company Limited**

No. 502B, 6th Floor, B Wing,
Shriram Shyam Towers,
Near LIC Square, Sardar,
Nagpur - 440 001.
Phone : 0712-2569932
Email : Service.Nagpur@tvs motor.com
AO.Rajpur@tvs motor.com

GUJARAT**8. TVS Motor Company Limited**

1208-1213, Shivalik Satyamev,
Below Bopal Over Bridge,
Ambli-SP Ring Road Junction, Bopal,
Ahmedabad- 380058.
Phone : 079-65443748
Email : AO.Ahmedabad@tvs motor.com

MADHYA PRADESH-1 & 2**9. TVS Motor Company Limited**

No. 211-212, 2nd Floor,
Chinar Incube Business Centre,
Chinar Fortune City,
Near Brindhavan Dhaba,
Hosangabad Road,
Bhopal - 462 026.
Phone : 0755-2499406/2499306
Email : AO.Bhopal@tvs motor.com
AO.Indore@tvs motor.com

RAJASTHAN-1 & 2**10. TVS Motor Company Limited**

Plot No. 17-18,
2nd Floor of National Motors Building,
Jhotwara Industrial Area,
Jaipur - 302 012.
Phone : 0141-5150901/5150902
Email : AO.Jaipur@tvs motor.com
AO.Udaipur@tvs motor.com

DELHI & HARYANA**11. TVS Motor Company Limited**

D-3 & D-4, 2nd Floor,
Sector - 10, Noida,
Uttar Pradesh - 201 301.
Phone : 011-29834640/29834773
Email : AO.Delhi@tvs motor.com

PUNJAB & CHANDIGARH**12. TVS Motor Company Limited**

4th Floor, Royal Business Park,
Chandigarh Ambala Highway,
Zirkapur - 140 603.
Phone : 01762-464777/465777
Email : AO.Chandigarh@tvs motor.com

UTTAR PRADESH WEST**13. TVS Motor Company Limited**

D-3 & D-4, 2nd Floor,
Sector - 10, Noida,
Uttar Pradesh - 201 301.
Phone : 011-29834640/29834773
Email : AO.Delhi@tvs motor.com

UTTAR PRADESH CENTRAL & EAST**14. TVS Motor Company Limited**

1st Floor, Cyber Tower, TC-34/N-2,
Vibhuti Khand, Gomti Nagar,
Lucknow - 226 010.
Phone : 0522-4918300/4918301
Email : AO.Lucknow@tvs motor.com

WEST BENGAL**15. TVS Motor Company Limited**

Ground Floor & First Floor,
133 A. S. P. Mukherjee Road,
Opp. Tollygunge Police Station,
Kolkatta - 700 026.
Phone : 033-24617096/24617092
Email : AO.Kolkatta@tvs motor.com

BIHAR**16. TVS Motor Company Limited**

N-Plaza, Jamal Road,
P.S. Kotwali,
Patna - 800 001.
Phone : 0612-2200068/2200069
Email : AO.BNJ@tvs motor.com

ORISSA & JHARKHAND

17. TVS Motor Company Limited

No. 303, 3rd Floor,
Creative Plaza, Rasulgarh,
Bhubaneswar - 751 010.
Phone : 0674-2580019
Email : AO.Bhubaneswar@tvs motor.com

NORTH EAST STATES

18. TVS Motor Company Limited

147, Udayan, Ganesh Guri,
Near Hotel D Courtyard,
R G B. Road, Guwahati - 781 005.
Phone : 0361-2202030/2202031
Email : AO.Guwahati@tvs motor.com

UNIQUE FEATURES OF TVS Scooty Pep+

ECO thrust CVTi' Engine

Your Scooter is powered by Next Gen 90cc Ecothrust CVTi engine with ignition map, higher spark energy, all Aluminum, higher efficiency charging system & improved fuel economy. It uses digital IDI ignition with inbuilt variable timing modes to ensure that you get the best from your engine.



Your scooter so has best in class Power to Weight ratio with best in class pickup. It makes your scooter smooth and zip through traffic with ease.

ECONOMETER®

Your speedometer has an ECONOMETER® which indicates whether you are riding in Economy Mode. This unique feature of your scooter enables to manage your scooter fuel efficiently.



LONG-IDLING INDICATOR

The long-idling indicator (economy mode blinking) reminds you to switch off the ignition while waiting at signals or when your scooter is idle, thus helping you to save fuel



EaZy® CENTER STAND

Your TVS Scooty Pep+ is fitted with a "Effortless Centre Stand" a unique feature to reduce the effort to place the vehicle on stand.



LIGHT WEIGHT

Optimum weight 93kgs



COMFORTABLE HEIGHT

Best in class ground reachability – 768mm



TELESCOPIC SUSPENSION

Makes bumpy rides more comfortable



SYNCHRONISED BRAKING TECHNOLOGY (SBT)#

Synchronised Braking Technology reduces the stopping distance, While keeping the stability intact.

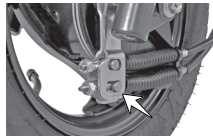

PARKING BRAKE (REAR BRAKE LOCK)#

The parking brake is another unique safety feature which protects your scooter from falling when it is parked on a slope.



GLOVE BOX

Your TVS Scooty Pep+ is fitted with unique feature of "Glove Box" to carry the small things weighing upto 3 kg.



BRIEFCASE HOOK

Your TVS Scooty Pep+ is fitted with yet another unique feature of "Briefcase hook" to carry the small things weighing upto 3 kg.

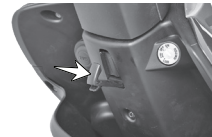

BAG HANGER

For more convenience, another luggage hook is locate just under the seat of your scooter



UTILITY BOX

Your TVS Scooty Pep+ is fitted with a "Utility box" has a large 10 litre under-seat storage space to carry your bags, books and belongings.



HELMET HOOK

Your TVS Scooty Pep+ is fitted with a "Helmet hook" under the seat assembly to conveniently place the helmet



MFR HEADLAMP

Your TVS Scooty Pep+ is provided with a “Multi focal reflector” - the bright headlamp with a ‘Halogen bulb’ for a better visibility in the dark.



LED DAY TIME RUNNING LAMP (DRL)

DRL increases the conspicuity of the vehicle during daylight conditions “Drive with safety and style.” Refer page no. 12 for details.



GLOW RING

Your TVS Scooty Pep+ is fitted with a unique feature of “Glow Ring” around the ignition lock for better visibility of lock location even in dark.



SMART PHONE CHARGER* (optional)

Your TVS Scooty Pep+ has a Smart phone charger enable to charge your mobile phone when you are traveling. Refer page no. 19 for operating procedure.



Dear Scooty Pep+ Owner,

Congratulations and welcome to the iconic world of Scooty Pep+. You are a proud owner of a scooter which has over 42 lakh happy customers all across the country.

You have made a perfect and smart choice by choosing the stylish Scooty Pep+. So go ahead and enjoy the comfortable and happy ride on India's No.1 Mileage Scooter.

Its new ECOTHRUST CVTi engine makes it more durable and ensures you have a long-lasting loving association with your Scooty. Also, telescopic suspension, EaZy* Centre stand will make all your rides wonderfully smooth.

This manual explains in detail, the many features, benefits and operations of your Scooty Pep+. Do read through your manual carefully, it will help you get the best out of your vehicle, and keep it going strong for years to come. To ensure reliable performance, we urge you to get your Scooty Pep+ serviced only at TVS Motor Company Authorized Main Dealers / Authorized Dealers at regular intervals as specified by your service provider.

We wish you peppy, comfortable, safe and awesome trips for many years to come!

Happy riding!

TVS MOTOR COMPANY LIMITED



This manual should be considered as a permanent part of the scooter and should remain with the scooter when resold or transferred to a new owner.

All information, illustrations, photographs and specifications contained in this owner's manual are based on the latest product information available at the time of this publication. TVS Motor Company Limited may, however, incorporate modifications or improvements on its vehicles at any time without notice, and therefore, in such events it is possible that the relevant part of the owner's manual does not apply to your vehicle.

Prior permission of TVS Motor Company Limited is required for quoting, copying or reproducing any part of this owner's manual.

i Note

Accessories shown in the picture may not be part of the standard equipment.

Your scooter is provided with a day time running lamp (DRL). The DRL glows automatically once the ignition is turned ON and continues to glow till the head lamp is switched 'ON'.

Since your vehicle is fitted with side stand cut-off system ensure to retract the side stand before starting the vehicle.

Operating this vehicle safely is an important responsibility of the rider. To help you make decisions on safety, we have provided necessary operating procedure and other information in this manual. This information alerts you on potential hazards that could hurt you or others. Since it is not possible to warn you about all the hazards associated with operating or maintaining the vehicle, you must use your own judgment.

You will find important safety information in following form in this manual. These words carry the following connotations:

Warning

*Disregarding this message might result in **injury to the rider or deadly accidents.***

Caution

*This message indicates special procedures or precautions to be followed to **avoid damage to the vehicle.***

Note

*This message provides further clarification for **clear understanding of any particular information.***

The first 1000 km is a crucial part of your scooter. Proper running-in operation during this period helps in ensuring a **maximum life** and **smooth performance** of your scooter.

The reliability and performance of your scooter depends on the special care and restraint exercised during the running-in period. It is especially important that you avoid operating the engine in high speed (RPM), which could expose the engine parts to excessive stress. Recommended speed during the running-in is:

Maximum 50 km/h speed upto 1000 km (vary the engine speed for better mating of parts).

The first free service at 500 ~ 750 km is most important. During running-in period all the engine components and other parts will have set in. All adjustments to be restored, all fasteners to be tightened. **Engine cum transmission oil to be replaced.** Timely performance of the first free service will ensure optimum service life and performance from the engine.



Caution

Replacing the engine cum transmission oil during first service is most important for better life of engine. Always use TVS TRU4 SKUUTA (SAE 10W30 API-SL, JASO MB) oil for better performance and life.

SAFE RIDING RECOMMENDATIONS

Any two wheeler riding requires some precautions to be taken to ensure the safety of the rider, pillion rider and other road users. These precautions are:

Familiarise yourself with new TVS Scooty Pep+

Riding skill and your mechanical knowledge form the foundation of safe riding practices. We suggest you to practice riding TVS Scooty Pep+ in a low-traffic condition until you are thoroughly familiar with your vehicle and its controls. Remember practice makes you perfect.

Riding apparel

Loose, fancy clothing can be uncomfortable and unsafe when riding a two-wheeler. Choose good quality two wheeler riding apparel.

Know your limits

Ride within the boundaries of your own skill at all times. Knowing these limits and staying within them will help you avoid accidents.

Warning

Two wheeler safety starts with wearing a good quality helmet. One of the most serious injuries that can happen is a head injury. Always wear an ISI approved helmet that should fit your head comfortably and securely. You should also have good quality goggles to protect your eyes and help your vision.

To prevent or minimize accident, never consume alcohol or drugs before or during the operation of your vehicle. Even minimal consumption of these will affect the rider's ability to control the vehicle.

Posture

Proper vehicle riding starts with proper posture.

1. Keep your elbows relaxed and flexible.
2. Sit and adjust yourself on seat so that arms and shoulders are relaxed.
3. Look widely instead of gazing at one point.

Warning

One-hand riding is dangerous. Keep both hands firmly on the handle bar and both feet securely on the floor board. Under no circumstances should both the hands be removed from the handle bar, as it is very dangerous.

Avoid use of mobile phones while riding as it could lead to fatal accident.

Slow down to a safe speed before negotiating a corner. If this is the first time that you are riding a vehicle of this type, we suggest that you practice on a safe, open area to become thoroughly familiar with the operation of the vehicle.

Cornering

When cornering, centrifugal force works in a direction perpendicular to the direction in which the vehicle is moving. Centrifugal force increases in proportion with speed and the radius of the corner.

During cornering, reduce speed so as to lessen the effects of centrifugal force. By all means, avoid abrupt application of brake or sudden steering.

Braking

For safe riding, it is very important to master the braking techniques.

1. Close / release the throttle.
2. Hold the vehicle upright as you apply the brake.
3. Progressive application of brake is safer.
4. **Apply both the brakes. 'SBT' provides additional braking even when 'Only Rear brake' is applied, But applying 'Both the brakes' helps you use the full potential of the brakes.**
5. Riding down hills, while cornering and wet roads close throttle and come to a slower speed to avoid the loss of control over the vehicle due to skidding.

Causes for poor braking

1. If the brake shoes or drum are worn out or if there is water or oil on them, sufficient friction does not develop and brakes do not work well.
2. Even when the brake works normally, if the road surface is wet or the tyre surface is worn-out, tyres do not take a firm hold on the surface, increasing the stopping distance.
3. Approximately 60% braking effect is from front brake. Non-usage of front brake causes poor braking.

Warning

As the vehicle speed increases, the stopping distance also increases progressively. Be sure that, you have sufficient distance between you and the vehicle or obstruction ahead of you.

Avoid directing the water jet directly towards brake drums during water wash.

*Using only the front or rear brake is dangerous and can cause skidding and loss of control. **Apply both the brakes together and with great care on a wet road or other slippery surfaces.** Any abrupt braking on slippery or irregular roads can cause loss of rider control.*

ACCESSORY INSTALLATION AND SAFETY TIPS

Use extreme caution while selecting and installing the accessories for your scooter.

The addition of **unsuitable accessories can lead to unsafe operating conditions.** Your friendly Dealer will assist you in selecting quality accessories and installing them correctly.

While selecting the accessories, make sure that the accessories **should not obstruct lighting, steering, suspension level and ground clearance.**

Additional electrical equipments is not acceptable as it will void warranty terms of the vehicle.

EMISSION CONTROL

All the TVS vehicles are tested in the factory for optimum fuel efficiency and CO levels. If the vehicle needs any adjustments, please consult nearest TVS Motor Company Authorised Main Dealer or Authorised Dealer.

While adequate care is exercised at the factory to ensure that the emissions are within the limits, it is essential for the owner to always maintain the scooter in good condition by getting it periodically checked and serviced by TVS Motor Company Authorised Main Dealer / Authorised Dealer so that the emission and fuel consumption levels are maintained as per norms.

Crankcase emission control system

The engine of new TVS Scooty Pep+ is equipped with a closed crankcase system to prevent discharging crankcase emissions into the atmosphere. Blow-by gas is returned to the combustion chamber through the air cleaner and the fuel system.

i Note

Your vehicle is tested and certified for emission which meets BSVI emission norms and is valid for initial 12 months from the date of purchase. Get your vehicle certified by the Government authorised emission testing station after initial 12 months of usage. And ensure to get the vehicle certified on expiry of the certificate obtained.

VEHICLE IDENTIFICATION NUMBER

Serial numbers of both frame and engine are required for vehicle identification. They are also required to assist your Dealer for ordering parts or referring to special information.



The frame serial number is stamped on the frame, at the rear end below the seat assembly. Open the seat assembly to read the frame number.

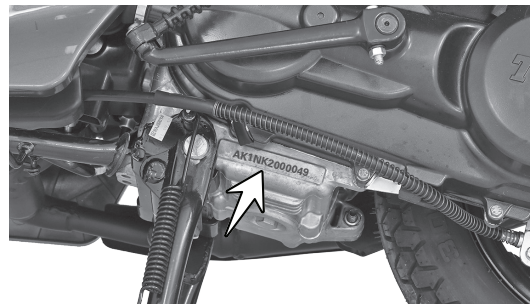

The engine serial number is stamped on the left side of the engine, at the bottom, near center stand mounting. See bottom to read serial number.



LOCATION OF PARTS - HANDLE BAR

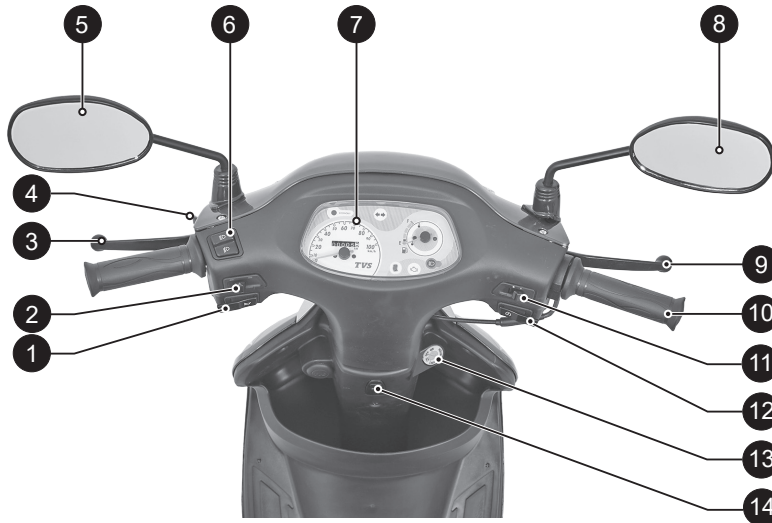

1. Horn switch
2. Turn signal lamp switch
3. Rear brake lever
4. Parking brake (rear brake lock)
5. Rear view mirror L
6. High / low beam switch
7. Speedometer assembly
8. Rear view mirror R
9. Front brake lever
10. Throttle grip
11. Lights ON/OFF switch
12. Electric starter switch
13. Ignition cum steering lock
14. Briefcase hook

CONTROL KEY

TVS Scooty Pep+ comes with a pair of identical control keys. These keys are to operate ignition cum steering lock, seat lock and fuel tank cap.

IGNITION CUM STEERING LOCK

TVS Scooty Pep+ is provided with a self illuminating ring (glow ring) around the ignition cum steering lock for better visibility of lock location in darkness. The three positions of the switch are described below.

1. 'OFF' position

All the electrical circuits are turned 'OFF' in this position. Engine will not start. Key can be taken out.



2. 'ON' position

In this position, all the electrical circuits are turned 'ON' and the engine can be started now. Key cannot be removed in this position.

3. 'LOCK' position

TVS Scooty Pep+ steering can be locked in both 'left' and 'right' directions.

Turn the handlebar to the 'left' or 'right'. Press the key IN and rotate it to the 'LOCK' position from 'OFF' position. All electrical circuits are deactivated and the steering is locked. Control key can be removed from the lock.

Insert the key into the lock and press the key IN and turn it to 'OFF' or 'ON' position to unlock the steering.

i Note

When you switch on ignition key, the pump priming noise may be heard, which is normal. Avoid frequent SWITCH-OFF & ON of ignition key, to avoid unnecessary run of fuel pump.

The speedometer back illumination, tail lamp and license plate lamp glow automatically once the ignition key is turned 'ON' without activating any other switches.

Caution

Leaving the ignition cum steering lock in 'ON' position will drain the battery when the vehicle is not in use. "Switch Off" and take the key out when the vehicle is not in use. For safety always lock the steering.

Warning

Never attempt to move the vehicle when the steering is locked, you may lose balance.

SPEEDOMETER ASSEMBLY

1. Speedometer

Indicates vehicle speed in kilometers per hour.

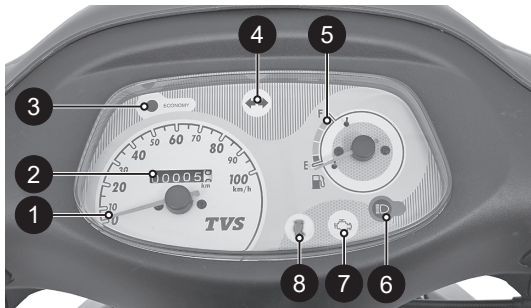

2. Odometer

Registers and displays the total distance covered by the vehicle in kilometers. The last digit denotes one tenth of a kilometer.

3. Economy indicators

Eco indicator (green lamp) indicates that the vehicle is running in economy mode which gives better fuel economy.

4. Turn signal indicator lamp (←→)

Flashes when the 'right' or 'left' side turn signal indication is activated.

5. Fuel gauge

Fuel gauge indicates the approximate quantity of fuel available in the fuel tank. Once the fuel indication is in red band (marked in the dial) re-fill the fuel as soon as possible.

Note

Always ride the vehicle in 'economy mode' for better fuel efficiency.

If the battery voltage is very low, economy mode lamp will blink once you switch 'ON' the ignition key till you start the vehicle. Electric starter will not work in this condition. Use kick starter only. Contact TVS Motor Company Authorised Main Dealer or Authorised Dealer.



Caution

When the fuel indication needle comes to E mark, fill fuel in the tank immediately to avoid engine switch OFF / damage to fuel pump which leads to replacement of pump without warranty.

6. High beam indicator lamp

Glows either when the head lamp high beam or the pass-by is activated.

7. Malfunction indicator lamp - MIL ()

MIL is turned ON when the ECU detects a fault in the system.

If the malfunction indicator lamp '  ' is glowing continually when the engine is started, immediately contact the nearest TVS Motor Company Authorised Main Dealer or Authorised Dealer.



Note

The malfunction indicator will continue to remain switched ON after ignition key ON until engine is started. But after starting the engine it will switch off if no malfunction is detected .

8. Side stand indicator**

The side stand warning indicator turns 'ON' to alert you whenever the vehicle's side stand is deployed (vehicle parked condition).



Note

If the side stand is deployed the vehicle will not start. Retract the side stand to start the vehicle.

When there is no indication pop up in speedometer and the vehicle is not switching 'OFF' in stand deployed condition (vehicle parked condition), it indicates the failure in the side stand switch. This failure not allowing the vehicle to stop when the side stand is deployed. As a safety measure it is recommended to visit nearest TVS Motor Company Authorised Main Dealer / Authorised Dealer for rectification.

** Side stand indicator lamp will be applicable only for the vehicles produced after April 2022. For the vehicles produced between Jan 2022 to March 2022, when there is a failure in the side stand switch, vehicle will not switch 'OFF' when the side stand is deployed. Please visit the nearest TVS Motor Company Authorised Main Dealer / Authorised Dealer for rectification.

LED DAYTIME RUNNING LAMP (DRL)

TVS Scooty Pep+ comes with a day time running LED lamp which glows automatically once the ignition is turned ON and continue to glow till the head lamp is switched 'ON'.

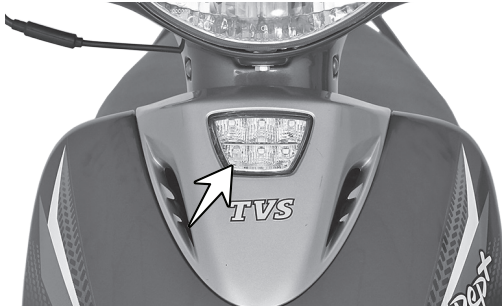

i Note



DRL lamp goes 'OFF' automatically once the head lamp is turned 'ON'.

HANDLE BAR LEFT SIDE

1. Horn switch

Press the switch '  ' to operate the horn.

2. Turn signal lamp switch

Slide the turn signal lamp switch to left '  ' or right side '  ' to operate respective turn signal lamps (LH / RH). Press the switch to turn 'OFF'.

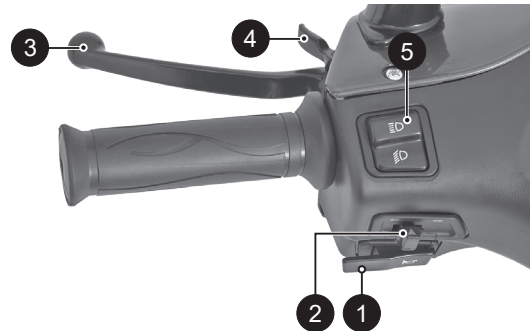

⚠ Warning

Always use the appropriate turn signal lamps when you intend to change lanes or take turns. Be sure to switch 'OFF' it after negotiating the lanes or turns.

3. Left hand brake lever (SBT brake lever)

Synchronised Braking Technology (SBT) can be operated by pressing the left hand brake lever gently towards the handle grip.

SBT technology helps to operate both front and rear brakes by distributing the force optimally between the two braking system.

4. Parking brake (rear brake lock lever)

Brake lock protects your scooter from rolling-off, when parked on side stand (or) helps you relax while waiting in a long traffic signal (or) a slope.

To activate brake lock, press the brake lever almost half towards the grip and hold, then press the parking brake lever to maximum and release the brake lever slowly. Ensure the brake is locked properly. Pressing the brake lever further releases the brake lock automatically.

Warning

Since your vehicle is fitted with SBT brake system it is essential to maintain the brake system in good condition. Adjust the brakes system at regular intervals for the proper working of SBT.

Ensure release the brake lock before riding the vehicle.

5. High/low beam switch

With the head lamp 'ON', press the switch towards '☰' to operate head lamp high beam or press it towards '☷' to operate head lamp low beam.

Warning

Use appropriate head lamp beam 'high / low' as per the traffic and road conditions for your safety and to avoid inconvenience to other riders. It is strongly recommended to ride the vehicle in 'low beam' during day.

HANDLE BAR RIGHT SIDE

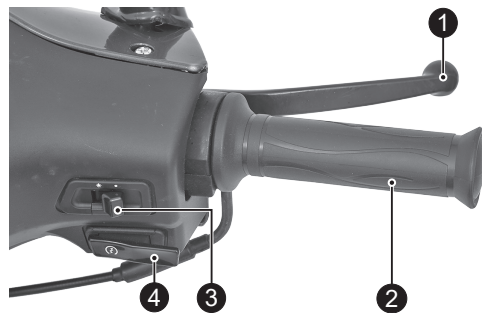

1. Right hand brake lever

Front brake system can be operated by pressing the right hand brake lever gently towards the throttle grip. The brake lamp glows on application of either right hand or left hand brake lever.

2. Throttle grip

Engine speed is controlled by the rotation of the throttle grip. Twist it towards you to increase the engine speed and twist it away from you or release it to decrease the engine speed.

3. Light switch

Light switch has the following position. Working of switch at various position are as follows:

OFF: All the lamps are turned 'OFF' except DRL lamp and tail lamp when the switch is positioned at ' ' even though the engine is running.

ON: The head lamp, speedo lamp, tail lamp and license plate lamp glows when the switch is positioned at ' ' and engine is running.

4. Electric starter switch

Retract the side stand and press the starter switch '⚡' to start the engine electrically along with the application of either front or rear brake.

FUEL TANK* CAP

Fuel tank is located at the rear end of the vehicle under the seat. To open the seat, insert the control key into the seat lock and rotate it in clockwise direction and lift the seat.

Remove the fuel tank cap by rotating it in anti-clockwise direction and fill the fuel as recommended. Refit the cap and lock the seat by gently pressing the rear end of the seat until you hear a '**click**' sound and take out the key.

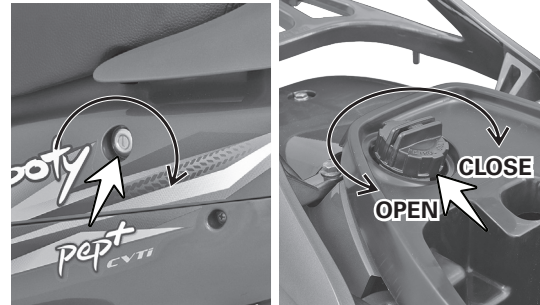

**The fuel tank is not a measuring instrument and the capacity of the fuel tank may slightly vary from the indicated capacity.*

 **Caution**

Ensure that the fuel gun is inserted fully into the tank neck while refueling.

Whenever refueling, fill upto the bottom of the neck portion (insert level) of the fuel tank. Filling above the neck may result in improper breathing of fuel tank and seepage of fuel.

While refueling, avoid spillage of petrol on the tyre. If fuel spills on tyre, the tyre will loose its grip on the road. Ensure to close fuel tank cap without fail to avoid fuel spillage.

 **Warning**

Never refill fuel near open flame. Do not smoke while refueling. Do not use cell phones while refueling.

KICKSTARTER LEVER

The kickstarter lever is located on the left side of the vehicle. To start the vehicle, keep the ignition in 'ON' condition and apply the rear brake as a safety precaution to prevent the rear wheel rotation.

Keep your foot on the lever extension as shown in the figure. Kick the lever from top and stroke to bottom with rapid motion.

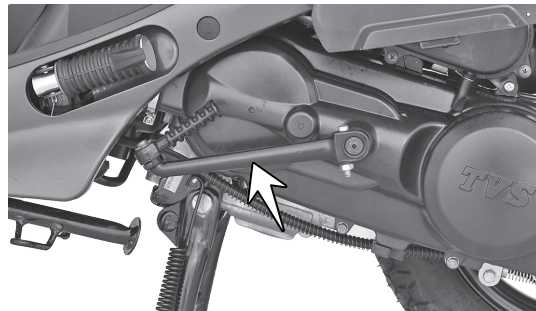

EFFORTLESS E-Z CENTRE STAND

TVS Scooty Pep+ is equipped with a effortless centre stand (1) and a side stand (2). The centre stand has a pivoted flexible spring loaded lever arm (stand extension) (1a) to increase the lever ratio, which enables parking on centre stand effortlessly and very conveniently.

To place the vehicle on the centre stand, hold the handle bar left grip with left hand. Place your foot firmly on the stand extension (1a) and press.

Side stand (2) can be operated by sitting on vehicle with your left foot by pushing it away from the vehicle till it stops.

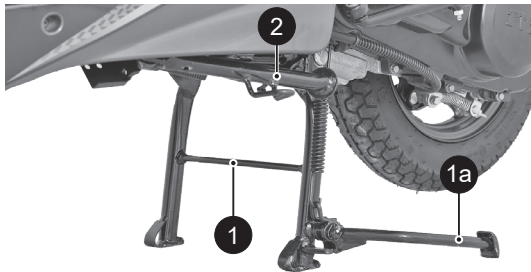

Warning

Always retract the side stand to its full up position before moving the vehicle. Else, the vehicle will not get start.

Caution

Never sit on vehicle when it is supported by stands. Always park the vehicle on a flat, firm surface.

TOOL KIT AND FIRST AID KIT

To assist you in performing certain aspects of periodic maintenance and emergency repairs, a tool kit is supplied along with the vehicle and it is located below the seat base. To access the tool kit, insert the control key into seat lock and rotate it in clockwise direction. Lift and open the seat.

The tool kit consists one number each of the following. Ensure the contents of the tool kit.

1. 10x12 mm spanner
2. Combination screw driver bit
3. Screw driver handle
4. Tool bag



Caution

It is recommended to use the tool kit in case of any emergency only. It is always advisable to take your vehicle to TVS Motor Company Authorised Main Dealer / Authorised Dealer.



UTILITY BOX

Utility box is located below the seat. Lift the seat by unlocking the seat lock as explained earlier, to access the utility box.

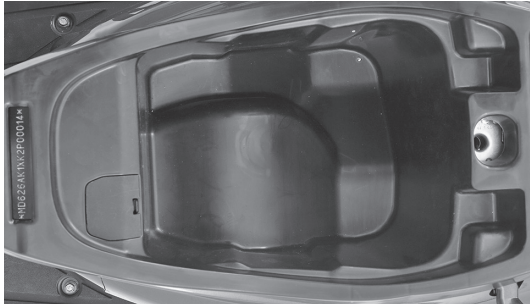

Warning

Operating the TVS Scooty Pep+ overloaded will hamper the riding stability and may lead to loss of control. Hence, it is advisable to carry the recommended amount of load only.

Caution

Utility box can be used to carry a load of 10 kg maximum.

Do not carry perishable items inside the utility box. It is not fully sealed. Do not allow / spray water to get inside the utility box. Take care not to spill petrol or oil into the utility box.

*Do not keep heat-sensitive items inside as it may get hot on long rides. **Do not keep valuable items inside the utility box when leaving the vehicle unattended.***

GLOVE BOX

Glove box is provided to store easy and quick access things like notebooks, file etc.



Warning

Do not keep valuable items inside the glove box when leaving the vehicle unattended. Do not carry perishable items inside the glove box. It is not fully sealed.

HELMET HOOKS

Two helmet hooks are provided under the seat assembly at front end near the seat hinge to secure your helmet. Open the seat assembly (refer page No. 26) to access the helmet hooks. Hook the helmet strap in the helmet hook properly and close the seat assembly.



BRIEFCASE HOOK

Briefcase hook is located below handle bar on the rear panel. Just pull out the hook from the top (A) to hang your luggage. A briefcase / leather bag weighing upto 3 kg can be hung on this hook. Be sure to push back the hook the after use.

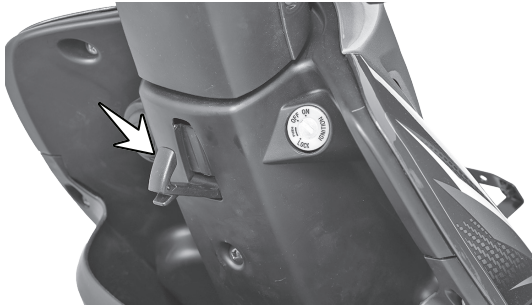

Caution

Operating the TVS Scooty Pep+ overloaded will hamper riding stability and may lead to loss of control. Hence, it is advised to carry recommended amount of load only.

BAG HANGER

Bag hanger is provided below the front end of the seat assembly near seat hinge. Luggage can be hung on both sides of the bag hanger.



Warning

Bag hanger can be loaded upto a maximum of 1.5 kg. Load the cargo evenly both the sides and center oriented. Otherwise it may lead to loss of control.

SMART PHONE CHARGER*

This smart phone charging socket enables you to charge your smart phone when you are traveling.

This socket is located below left side of handle bar. Please go through the operating manual of the mobile phone and use a suitable adaptor for the battery operation recommended by the mobile phone manufacturer for that particular model. Please follow the guidelines provided for the proper usage of the socket :-

DO's

1. Ensure that no water enters into the socket, by closing the USB flap properly.
2. Use only mobile phone company's authorized USB cable for mobile charging.
3. Do make sure the flap is not damaged while opening / inserting the USB cable.

DON'TS

1. Do not leave the USB charging flap open / partially closed.
2. Do not attempt to use / charge any other device, other than one mobile phone at a given time.

* Mandatory and optional accessory will be charged extra

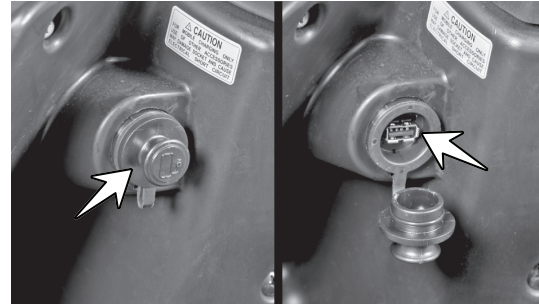

3. Do not try to force the USB connector in, check if it is inserted in the appropriate direction, to prevent damage.
4. Do not charge your mobile when the engine is in OFF condition.
5. Do not use other device, this port is for charging mobile phones only.

Caution

Secure your mobile phone properly during charging and protect it from any liquid, dust etc.

Take the mobile phone and the usb cable along with you while the vehicle is parked or unattended.

PRE RIDE INSPECTION

Check the following items before riding

| ITEM | WHAT TO CHECK FOR |
|-----------------------|---|
| Engine oil | Availability of oil upto the level (page No. 47) |
| Transmission oil | Availability of oil upto the level (page No. 47) |
| Fuel | Enough fuel for the planned distance of running |
| Tyres | Correct pressure (page No. 52) |
| | Adequate tread depth / No cracks or cuts. |
| Battery | Proper working of electric starter, horn, fuel gauge, brake lamp, tail lamp, speedo back illumination, license plate lamp and turn signal lamps. Electrolyte level (page no. 29) |
| Lighting | Proper working of head lamp high / low beam and high beam indicator |
| Steering | Smooth movement / No play or looseness |
| Throttle | Correct free play of cable / Smooth operation |
| Brakes | Correct front and rear brake lever play (page No. 48 & 51) |
| Wheels | Free rotation |
| Malfunction indicator | Turned OFF after the engine is started (page No. 20) |

Caution

Do not switch 'ON' the ignition without minimum level fuel in tank. It will cause damage to the fuel pump.

STARTING THE ENGINE

Ensure availability of fuel in the fuel tank. Insert the control key into the ignition cum steering lock and turn it to the 'ON' position. In side stand retracted condition, apply any one of the brake and press the electric starter switch to start electrically or kick start. Press the start button without applying the throttle. As soon as the engine starts, release the start button. The engine will not start if the throttle is opened full.

Setting the vehicle in motion

1. Twist the throttle grip slowly towards you and simultaneously release the brake lever gently and smoothly. The vehicle will start moving forward.
2. As the vehicle picks up speed, increase the throttle slowly.



Caution

Do not keep the engine in idling rpm for long and do not open excessive throttle when the vehicle is parked. It leads to overheating of engine and damage to the internal components.



Warning

Do not raise the throttle rapidly so the vehicle will move forward suddenly and lead to loss of control.

Stopping and parking

1. Close the throttle completely and apply both the brakes simultaneously.
2. Turn the ignition 'OFF'.
3. Park the vehicle on a firm, flat surface.
4. Lock the steering and take out the control key. Finally close the safety key shutter lock.



Warning

Reduce speed to a safe limit before turning / cornering. Do not apply brake while turning / cornering.

FUEL RECOMMENDATION

Use only BS VI petrol with minimum RON 91.

BS VI petrol containing upto 10% of ethanol by volume can be used.

Higher ethanol content in petrol can

- degrade plastic and rubber components of fuel system and vehicle parts
- cause corrosion damage to metal parts like fuel tank, etc
- result in startability & drivability issues
- decrease fuel economy

Ethanol absorbs water very easily, resulting fuel separation. Extra care shall be taken to prevent moisture entry into fuel tank while filling ethanol blended petrol and water washing of vehicle.

Painted parts (viz. panels, covers) shall not come in contact with ethanol blended fuels.

Manufacturer is not responsible for any warranty issues that results from using ethanol blend in excess of 10% by volume.

In case of any abnormalities observed due to use of ethanol blended fuels, customers are advised to use a different fuel station/brand for standard E10 fuel or contact authorised service centres.

 **Caution**

Never mix oil in petrol in the fuel tank. Always fill fuel from the reputed and reliable fuel stations.

CHECKS AND TIPS FOR IMPROVING FUEL ECONOMY

Regular checks

Carry out the periodic maintenance checks as specified in this manual (page No. 37).

Regular maintenance checks will save fuel and ensure trouble-free, enjoyable and safe riding besides keeping environment clean.

Spark plug

A dirty or defective spark plug leads to wastage of fuel due to incomplete combustion. Clean and adjust the spark plug only if necessary. Replace the spark plug every 12000 kms (1 year). Always use recommended spark plug only.

Air cleaner element

A dirty air cleaner element restricts airflow and increases fuel consumption. Replace the element every 12000 kms.

Since paper filter is used in your scooter it is not recommended to clean the filter. Replace the filter incase of any abnormalities.

Engine oil and Transmission oil

Dirty or less engine oil increases friction between various parts of the engine and reduces the engine life, thereby increases the fuel consumption.

Running with low transmission oil will cause damage to the gears and bearings.

Regularly inspect the engine oil and the transmission oil for correct level and top-up if necessary. Get it replaced at regular intervals as per the maintenance schedule.

Fuel leak

Inspect and arrest fuel leaks if any from tank and fuel lines. Loss of fuel due to leak may drain the fuel tank completely.

Evaporation

Vehicle parked in the hot sun leads to wastage of fuel through evaporation. Also, lower fuel levels in the tank will have increased evaporation and condensation of moisture inside.

Ensure to close fuel tank cap after every filling. If the fuel tank cap kept open for long time, it leads to safety and fuel loss.

Tyres

Low tyre pressure has adverse effect on the vehicle. The **drag on the vehicle** increases resulting decreased fuel economy. Further more, handling may be adversely affected.

Inspect the tyre pressure regularly (weekly) and inflate it to the recommended pressure (refer page No. 52). Never use tyres which are worn beyond the permissible limit.

Wheel freeness

Inspect and ensure the wheel freeness by rotating the wheel at least once in a week to avoid wastage of fuel.

Avoid unnecessary idling

While waiting for someone or stopping in signals for long time, if the engine is kept running at idle speed, it causes unnecessary wastage of fuel.

Avoid frequent braking

Anticipate corners and slopes as well as the traffic conditions. **Unnecessary and frequent braking will reduce the fuel economy. Never accelerate and apply brake simultaneously.** It leads clutch shoes wear and wastage of fuel.

i Note

The on-road mileage of TVS Scooty Pep+ is dependent on several factors like Road condition, Quality of fuel, Riding speed, operation of Clutch and Brake, Tyre inflation, Maintenance / timely servicing of vehicle, load etc. and hence will differ from the mileage given under standard test conditions such as made in recognised institutes.

MAINTENANCE SCHEDULE

The maintenance schedule indicates the intervals between periodic services. At the end of each interval, be sure to inspect, check, replace, adjust, lubricate and service as instructed. If the maintenance is not done periodically, it will result in rapid wear and severe damage to the vehicle. If the vehicle is used under high stress conditions such as continuous full throttle operation or if used / operated in dusty climate, certain jobs should be performed more often to ensure reliability of the vehicle. Cylinder head, steering components, suspension and wheel components etc., are key items and require very special and careful servicing. TVS Motor Company Limited strongly recommends that the jobs as per the maintenance schedule be performed by your TVS Motor Company Authorised Main Dealer / Authorised Dealer.

Periodic inspections may reveal one or more parts that may need replacement. Whenever replacing parts on TVS Scooty Pep+, it is recommended that you use only the **TVS Motor Company Genuine** parts.



Caution

Proper running-in and maintenance are mandatory for making certain that your vehicle is reliable and gives optimum performance at all times. Make sure that the periodic maintenance is performed thoroughly in accordance with the instructions given in this owner's manual.

In more dusty areas, the air filter element required early replacement than the mentioned kilometers to avoid costly damages to the engine.

PERIODIC MAINTENANCE SCHEDULE (months or km whichever occurs earlier)

| Item | Service km | In free service | | | | After free service | | Remarks |
|--------------------------------------|---------------|------------------------------|--------------------------------|--------------------------------|---------------------------------|------------------------------|------------------------------|---|
| | | 1st 500 - 750 2 months | 2nd 2500 - 3000 4 months | 3rd 5000 - 6000 8 months | 4th 8500 - 9000 12 months | Every 3000 km 4 months | Every 6000 km 8 months | |
| Engine oil | | R | I & T | R | I & T | I & T | R | |
| Oil filter (strainer) | | C | - | C | - | - | C | |
| Transmission oil | | R | I & T | R | I & T | I & T | R | |
| Spark plug | | C & A | - | - | - | - | - | Inspect, Clean and adjust if required, Replace every 12000km |
| Air cleaner element ¹ | | I & C | I & C | I & C | I & C | I & C | - | Replace every 12000 km |
| CVT filter element ¹ | | - | - | I & C | - | - | I & C | Replace every 12000 km |
| Fuel pump filter | | - | - | - | - | - | - | Inspect and replace every 21000 km |
| Tappet clearance | | I | - | I & A | - | - | I & A | Inspect for any noise / starting trouble and adjust if required |
| Drive belt | | - | I | I | I | I | - | Replace every 15000 km |
| Cover variator ² | | - | - | I, C & L | - | - | I, C & L | |
| Clutch shoe and housing clutch | | - | - | I & C | - | - | I & C | Replace shoe every 15000 km |
| Face complete movable / fixed driven | | - | - | L | - | - | L | Lubricate using grease |
| Hose fuel | | I | I | I | I | I | - | Replace every 3 years |
| SAI hose | | I | - | - | - | - | - | |
| Front and rear suspension | | I | I | I | I | I | - | Inspect for proper functioning |

R - Replace; I - Inspect; T - Top up; C - Clean; A - Adjust; L - Lubricate; TI - Tighten; S - Set; Ro - Rotate

¹ Inspect for any damage ² Clean with air. Lubricate kick starter using grease

³ Inspect for proper operation and adjust play. Lubricate ends using grease

Contd...

| Item | Service km | In free service | | | | After free service | | Remarks |
|---|---------------|-----------------------|-------------------------|-------------------------|--------------------------|------------------------------|------------------------------|--|
| | | 500 - 750 2 months | 2500 - 3000 4 months | 5000 - 6000 8 months | 8500 - 9000 12 months | Every 3000 km 4 months | Every 6000 km 8 months | |
| All control cables ³ | | I, A & L | I, A & L | I, A & L | I, A & L | I, A & L | - | |
| Throttle grip | | - | - | L | - | - | L | Lubricate using grease |
| Steering smooth operation / play ⁴ | | I & A | I & A | I & A | I & A | I & A | - | C & L with fresh grease every 12000 km |
| Speedometer cable and hub drive | | - | - | L | - | - | L | Lubricate using grease |
| Front fork oil | | - | - | - | - | - | - | Replace every 24000 km |
| All fasteners | | I & TI | I & TI | I & TI | I & TI | I & TI | - | |
| All bulbs, horn & switches | | I | I | I | I | I | - | Inspect for proper functioning |
| Head lamp beam | | I & A | I & A | I & A | I & A | I & A | - | |
| Battery electrolyte level | | I & T | I & T | I & T | I & T | I & T | - | |
| Specific gravity & voltage ⁵ | | I | I | I | I | I | - | |
| Malfunction indicator lamp | | I | I | I | I | I | - | <i>Check and resolve the errors using diagnostic tool if the lamp is ON even after starting the engine</i> |
| Brakes effectiveness / play | | I & A | I & A | I & A | I & A | I & A | - | |
| Brake cam | | - | - | C & L | - | - | C & L | Lubricate using grease |
| Wheel freeness | | I | I | I | I | I | - | |
| Tyre pressure at cold condition | | I & S | I & S | I & S | I & S | I & S | - | |
| Tyre rotation | | - | RO | RO | RO | RO | - | |

R - Replace; I - Inspect; T - Top up; C - Clean; A - Adjust; L - Lubricate; TI - Tighten; S - Set; Ro - Rotate

⁴ Adjust play if required ⁵ Recharge if necessary

| Item | Service km | In free service | | | | After free service | | Remarks |
|---------------------------|---------------|------------------------------|--------------------------------|--------------------------------|---------------------------------|------------------------------|------------------------------|--------------------------|
| | | 1st 500 - 750 2 months | 2nd 2500 - 3000 4 months | 3rd 5000 - 6000 8 months | 4th 8500 - 9000 12 months | Every 3000 km 4 months | Every 6000 km 8 months | |
| Fuel tank assembly** | | I & C | I & C | I & C | I & C | I & C | – | |
| Center / side stand pivot | | L | L | L | L | L | – | Lubricate using TRU4 oil |
| Kick starter pedal pivot | | L | L | L | L | L | – | Lubricate using TRU4 oil |

R - Replace; I - Inspect; T - Top up; C - Clean; A - Adjust; L - Lubricate; TI - Tighten; S - Set; Ro - Rotate

** Check for abnormal vehicle jerk / noise while opening the cap / leak. If found any, contact TVS Motor Company Authorised Main Dealer or Authorised Dealer.

RECOMMENDED LUBRICANTS

| APPLICATION | QTY | MANUFACTURER | BRAND |
|------------------|---|---|--|
| Engine oil | 750 ~ 800 ml (during regular service) 800 ml (incase of disassembly) | TVS Motor Company | TVS TRU4 SKUUTA oil SAE 10W/30 API-SL, JASO MB) |
| Transmission oil | 100 ml (during regular service) 120 ml (incase of disassembly) | -do- | -do- |
| Front fork oil | 53 ± 1 ml / leg | IOC / Castrol | Gabriel Premium front fork oil |
| Grease | - | Bharat petroleum IOC Bechem Kluber Lubrication | MP Grease no. 3 Servo Gem no. 3 Bechem premium grade 3 Kluber Centoplex 2 |

SELF - MAINTENANCE PROCEDURES

Battery is located at the front end near seat hinge below the seat assembly. The electrolyte level of the battery must be maintained to avoid damages to the battery. Follow the procedure to check the electrolyte level:

1. Open the seat assembly as explained in page no. 13 and take out the utility box.
2. Inspect battery electrolyte level. It should be between minimum and maximum level.
3. If the electrolyte level is below minimum level, add only distilled water upto the maximum level by removing the filler caps.

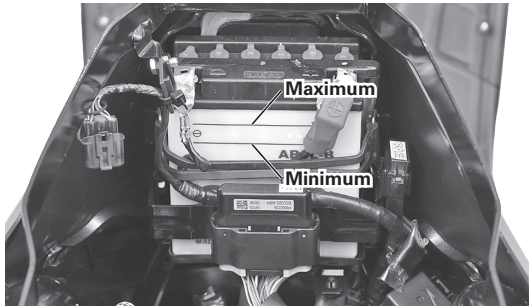

4. Reinstall the filler caps and clean the battery thoroughly, apply petroleum jelly to the battery terminals to protect it from corrosion.

In case of any abnormality or for removal of battery from the vehicle, contact TVS Motor Company Authorised Main Dealer / Authorised Dealer.



Caution

Once the battery is charged initially, never add diluted sulphuric acid. Use only distilled water for topping up. Never add tap water.

Never check the battery charge by shorting the terminals. Always connect the positive terminal first and then negative to avoid sparking.

Do not obstruct, bend or change the routing of battery air vent tube. Make sure that the vent tube is firmly attached to the battery and the other end is open and clear.

Recommendations to maintain battery health during prolonged parking conditions

While your vehicle is parked for prolonged duration, battery continues to discharge and if left unattended can get completely discharged. It is recommended to ride the vehicle for minimum 60 km every week to keep the battery in healthy condition. This could be at a stretch in one ride or several rides during the week.

The vehicle speed will vary during the ride but an average speed of minimum 30 kmph will be helpful to ensure proper battery charging. Use kick-starting, if available, to conserve battery charge during such period. This is only a recommendation to maintain battery charge and regular service schedules must be followed to maintain your vehicle in good running condition.

The following is recommendations to users regarding battery maintenance before, during and after long storage of battery:

1. Before Storage

- a. Store the battery only after fully charging it
- b. Battery fuse to be disconnected and stored safely. This will reduce the sleep mode current and hence enhance storage life of battery.*

- c. Alternatively, battery connecting wires (positive and negative wires) can be disconnected and fasteners can be secured with battery terminals.*

2. During Storage

- a. Store it at room temperature or lower.
- b. Store the vehicle in the shade and protected from rain and cover the vehicle to prevent rodents from entering and damaging the wires.

3. After Storage

- a. Connect the wires and fuse, if disconnected earlier, with ignition switch in OFF position*
- b. Start the vehicle by kick starting.

(Above recommendations do not consider storage effects on other systems such as induction and fuel systems and wheels)

* To be done by skilled personnel

Periodic Maintenance of Batteries:

- Keep top of battery clean
- Check cables, clamps, and case for obvious damage or loose connections
- Clean terminals and connectors as necessary
Recharge battery if voltage is below 12.4V.

Valve Regulate Lead Acid (VRLA) / Lead Acid batteries are prone to water damage. Any water entry, through vents or otherwise; will result in irreparable damage to the battery or the vehicle.

 Warning

Battery develop explosive gases. Keep it away from heat sources. If charging is required the battery must be charged in well ventilated area.

Unusable battery must be disposed in environment friendly manner. Do not discard it with household thrash. Handover the battery to the battery dealers or to a recycle center that accept used battery.

 Caution

Never operate the vehicle with discharged battery as it may damage electrical components.

Do not push start the vehicle, use a good battery to start the vehicle.

FUSE REPLACEMENT

Non-working of electrical systems may be due to safety fuse failure. Short circuit or overload in the electrical system are the main cause for fuse failure. Two different fuses are provided in TVS Scooty Pep+ they are:

- Main fuse - 15A
- Load fuse - 10A

The main fuse is located near the battery and the load fuse is located at the front of vehicle inside the front panel.

Follow the procedure given below to inspect and replace the fuse:

Main fuse

1. Open the seat assembly as explained in page no. 13 and take out the utility box.
2. Fuse case fitted on the near battery contains a 15A fuse. Pull out the fuse case from frame bracket. Open the fuse case and take out the fuse.
3. Inspect the fuse for failure. If found defective, replace the fuse with the extra fuse provided in the wiring harness itself.
4. Close the fuse case and re-fix into the battery band.

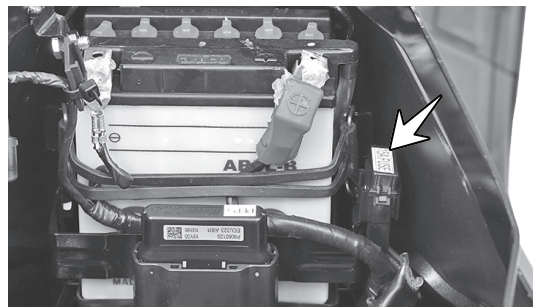

5. Turn 'ON' the ignition lock and check for proper functioning of electrical systems. In case the fuse fails again, consult the nearest TVS Motor Company Authorised Main Dealer / Authorised Dealer.

Load fuse

1. Open the front panel.
2. Fuse case fitted on the frame contains a 10A fuse. Pull out the fuse case from frame bracket. Open the fuse case and take out the fuse.
3. Inspect the fuse for failure. If found defective, replace the fuse with the extra fuse provided in the wiring harness itself.
4. Close the fuse case and re-fix into the frame bracket.

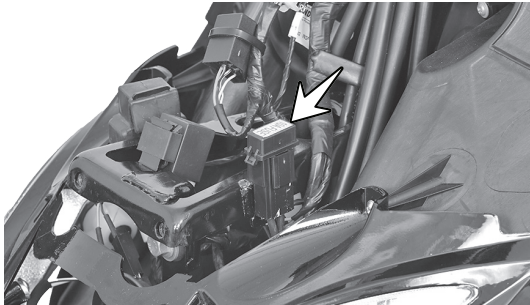

5. Turn 'ON' the ignition lock and check for proper functioning of electrical systems. In case the fuse fails again, consult the nearest TVS Motor Company Authorised Main Dealer / Authorised Dealer.

Good Fuse

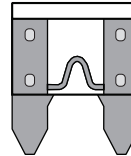

Blown Fuse

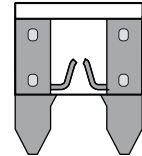

Caution

Do not use vehicle by **shorting the wires without fuse**. This may result in overheating of electrical items / wiring and may result in fire. Do not use fuse of higher amperage than specified for the safety of electrical system.

SPARK PLUG

To access the spark plug, the cover front has to be removed. Follow the procedure to remove the cover front.

1. Remove the cover front by removing the mounting screws.
2. Clean the dust and mud around the spark plug mounting to avoid falling inside the cylinder.
3. Pull out the suppressor cap from spark plug. Using spark plug spanner, remove the plug.

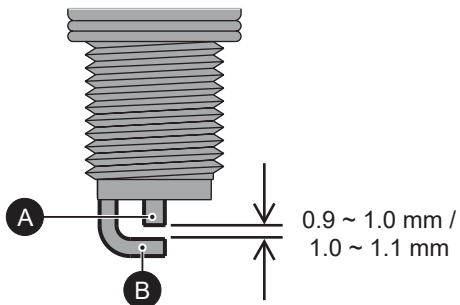

A spark plug with heavy carbon deposits will not produce strong sparks. Hence, only if necessary, clean the carbon deposits from the spark plug with a small wire brush or spark plug cleaning tool.

Inspect the spark plug electrodes (A) and (B) for any corrosion. If found any replace the spark plug with a new. Inspect the spark plug gap with a wire gauge / feeler gauge. Readjust the spark plug gap to **0.9 ~ 1.0 mm / 1.0 ~ 1.1 mm** if required.

After cleaning and adjusting the gap, reinstall the spark plug and tighten by hand to avoid cross threading. Finally tighten using spark plug spanner. Do not over tight.

After cleaning and adjusting the gap, reinstall the spark plug and tighten by hand to avoid cross threading. Finally tighten using spark plug spanner.



Caution

*Always use only recommended make and type of spark plug. **Replace spark plug every 12000 km.** Don't remove the spark plug when the engine is hot. Cover the spark plug hole with cloth when the plug is removed, to prevent dust / water entry. It is advisable to tighten the new spark plug by hand till the end, using plug spanner tighten by 1/4 turn. Then loosen the plug by 1/8 turn and re-tighten using plug spanner.*

ENGINE OIL LEVEL

Check the engine oil level periodically.

1. Place the vehicle on centre stand on a flat surface. Wipe-off the surroundings of gauge oil level.
2. Remove the gauge and wipe it clean.
3. Fix the gauge back to its mounting hole. Do not thread in.
4. Take out the gauge and check the oil level. The level should be between minimum and maximum level marks of the gauge (shown in the figure).
5. If the oil is less than the minimum level, add 'TVS TRU4 SKUUTA (SAE 10W30 API-SL, JASO MB)' oil upto the maximum level mark.

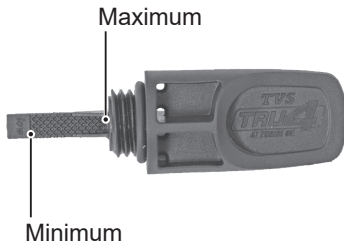

6. Wipe out the oil traces with a clean cloth to prevent dust accumulation.
7. Assemble back the gauge oil level.

TRANSMISSION OIL - LEVEL

Check the transmission oil level periodically.

1. Place the vehicle on centre stand on a flat surface.
2. Wipe-off the surroundings of oil level screw.
3. Remove the transmission oil level screw along with a gasket from the rear end of crankcase L.
4. Check for the flow of oil from oil level hole.

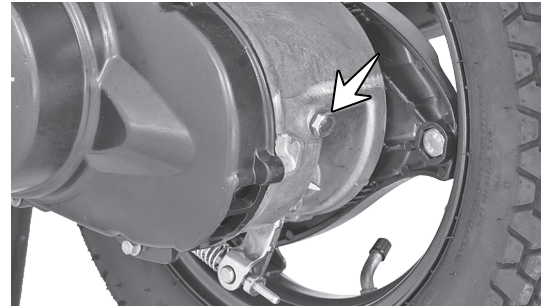

5. If the level is less (if there is no oil flow), top-up with 'TVS TRU4 SKUUTA (SAE 10W30 API-SL, JASO MB)' oil till the oil just starts to flow out from the oil level hole.
6. Wipe out the oil traces with a clean cloth to prevent dust accumulation.
7. Replace the fiber washer while reassembling the oil level screw.

**Caution**

If the vehicle is driven with less engine and transmission oil, the engine components will be severely damaged.

Check the oil level as per the schedule to avoid costly damage. Do not fill excess oil may cause oil leak. Always use 'TVS TRU4 SKUUTA (SAE 10W30 API-SL, JASO MB)' oil only.

BRAKES**Front brake - SBT**

1. Measure the free play of the front brake lever at lever end as shown in the figure.
2. The free play of the brake lever before the engagement of brake should be between 15 ~ 20 mm.
3. Turn the adjuster nut at the top (1) in the slot marked as "I" in clockwise direction for reducing the free play or in anti-clockwise direction for increasing the free play.

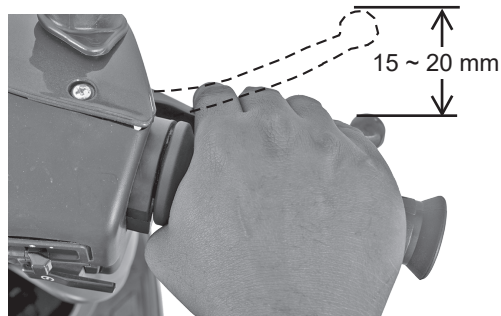

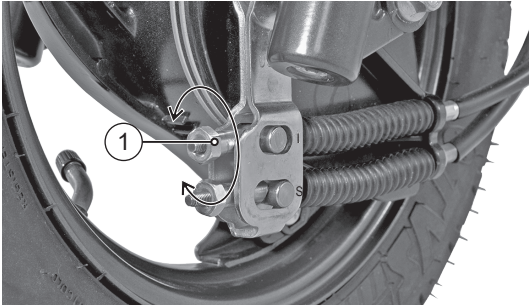

4. After obtaining the necessary free play, inspect for the clearance between the bullet (3) and slot end (4) marked as "S" as shown in the figure.

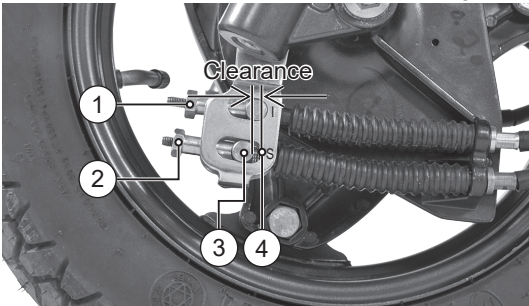

5. If any clearance is found, turn the adjuster nut (2) at the bottom side in the slot marked as "S" in clockwise direction until there is no clearance between the bullet bottom (3) and the slot bottom (4).

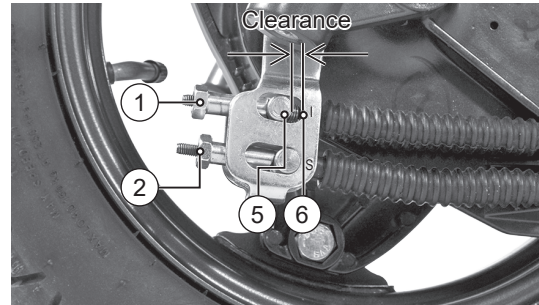

6. After adjusting the adjuster nut bottom, If any clearance is observed in between the bullet top (5) and the slot top (6) marked as "I" as shown, then turn the adjuster nut (2) in anti-clockwise until there is no clearance.
7. Once again check and confirm the brake play at the lever end.

Warning

Since the vehicle is fitted with Synchronised Braking Technology (SBT) adjust the brakes with additional care. If not it may result in brakes not working properly. Please contact TVS Motor Company Authorised Main Dealer or Authorised Dealer for any further assistance.

Brake shoe wear indicator - Front

When the brake is applied, wear limit index mark (1) on the front brake cam should be within the wear limit indicator (2) on the front brake panel.

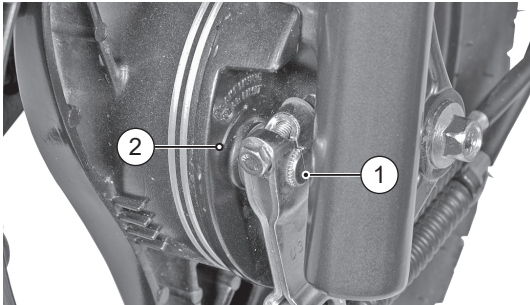

Incase the wear limit index mark (1) is going beyond wear limit indicator (2), index the lever to next slot with the help of the Dealer to extend the shoe life.

Caution

Replace the brake shoes as a set, if the wear limit indicator shows beyond the wear limit even after indexing the lever.

Rear brake

1. Measure the free play of the rear brake lever at the lever end as shown in the figure.
2. Free play of brake lever before the engagement of brake should be between 10 ~ 15 mm.

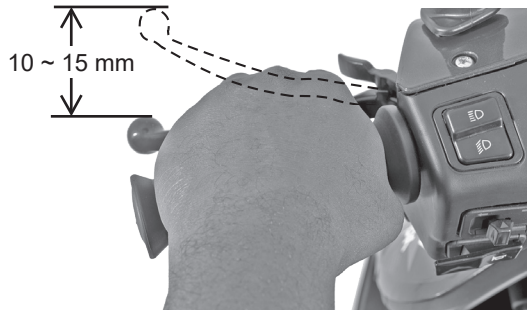

i Note

Please remember that the rear brake lever free play adjustment to be done only after adjusting the front brake lever play.



3. If the measured distance is more than the limit, adjust the nut provided at the rear wheel end to obtain the correct play.
4. Turn the adjuster nut in clockwise direction for reducing free play or in anti-clockwise direction for increasing the free play.

Brake shoe wear indicator - Rear

When brake is applied, the wear limit indication pointer (1) on the rear brake cam lever should be within the wear limit indicator (2) on the crankcase LH.

In case the wear limit indication pointer (1) is going beyond wear limit indicator (2), index the lever to next slot with the help of Dealers to extend shoe life.

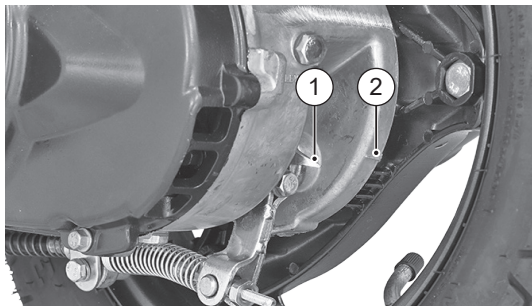

Caution

Replace the brake shoes as a set, if the wear limit indicator shows beyond the wear limit even after indexing the lever.

TYRES

Tyre pressure

Check the tyre pressure atleast once in a week if not more frequently. Insufficient air pressure in the tyres not only hasten the tyre wear, but also seriously affects the stability of the vehicle.

Under inflated tyres make smooth cornering difficult and over inflated tyres decreases the tyre contact with the ground which can lead to skidding and loss of control.

Be sure that the tyre pressure is within the specified limit at all times.

Tyre pressure in cold condition:

| | Solo | Dual |
|-------|----------------------------------|----------------------------------|
| Front | 1.69 kg/cm ² (24 PSI) | 1.69 kg/cm ² (24 PSI) |
| Rear | 2.04 kg/cm ² (29 PSI) | 2.50 kg/cm ² (36 PSI) |

Warning

The tyre inflation pressure in cold condition and the tyre tread condition are extremely important for the performance and safety of the rider. Check the tyres frequently for inflation pressure as well as the wear pattern on it. Use of a tyre other than the standard may cause instability.

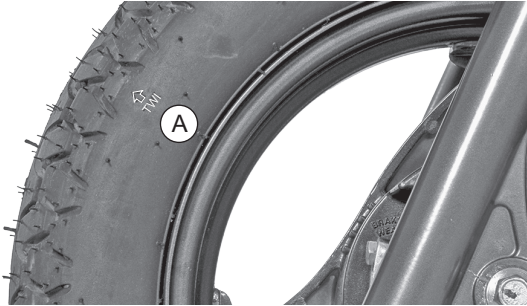

Tyre tread condition

Operating the vehicle with excessively worn tyres will decrease riding stability and can lead to loss of control. It is recommended to replace the tyre when the tyre wears off to the tyre wear indicator level (indicated by TWI (A) on the tyre).

Tyre rotation direction

While reassembling the tyres, after removing from the wheel rim, ensure that the arrow mark facing the direction of wheel rotation while fixing the tyre on the wheel rim.

Tyre Maintenance Tips

Inflation Pressure Check - Condition

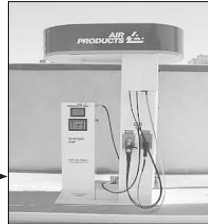

**Within
1 km**

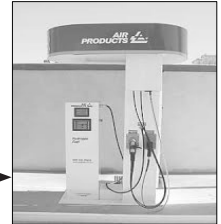

**Within
5 km**

i Note

If vehicle is in hold condition for long time

- Need movement of vehicle to avoid particular spot of tyre not to touch the ground for more than week time.
- Inflation pressure should check on cold condition maximum travel time should not exceed more than 1 km.
- Weekly basis inflation pressure check helps to improve 10% of tread life & fuel efficiency.

FRONT WHEEL REMOVAL AND REASSEMBLY

1. Remove the axle nut (A) along with washer.
2. Pull out the axle along with a washer from the wheel assembly. Remove a spacer from right side of the wheel.
3. Place a support below the foot board to prevent the vehicle from falling and lift the vehicle up.
4. Dislocate the wheel along with the brake panel and hub drive from the front fork. Separate the brake panel from the wheel and take out the wheel assembly.
5. Remove the wheel mounting nuts (3 nos) and separate the wheel assembly from the hub.

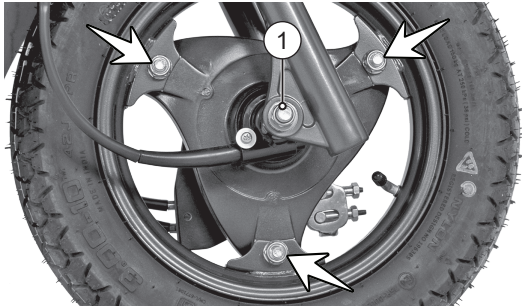

6. Reverse the procedure for reassembling. Locate the lug on fork leg L to the slot in the brake panel and lugs on the hub drive to the wheel hub while reassembling.

REAR WHEEL REMOVAL AND REASSEMBLY

1. Place the vehicle on centre stand.
2. Hold the rear brake firmly and remove the mounting nuts (3 nos). Slightly tilt the vehicle and take out the wheel.
3. Reassemble the wheel in the reverse order of removal. Hold the rear brake firmly while re-tightening the mounting nut for easy locking of wheel.



 **Warning**

Always make sure, whenever the wheel is removed, the axle nuts are tightened properly to the specified torque.

STORAGE PROCEDURES

For storage of your scooter for longer period of over a month and above, we recommend to carry out the following steps:

1. Clean the vehicle thoroughly. Park the vehicle on centre stand.
2. Warm up the engine and drain engine oil and transmission oil. Store the oil, if new, in a dust free container.
3. Empty the fuel tank.
4. Remove the spark plug and feed in several drops of engine oil through spark plug hole. Crank the engine few times and reinstall the spark plug.
5. Remove the battery, store it away from direct sunlight and freezing temperatures.
6. Place a suitable support at the bottom of the foot board so that both the tyres are off the ground. This will ensure better tyre life.

7. Cover up the vehicle completely with a clean tarpaulin or any other suitable cover. Store the vehicle inside a garage or similar area to avoid damage due to dust and rain. Make sure that the storage area is well ventilated and free from any source of flame or spark.

**Caution**

Do not park the vehicle on a slope or soft ground or else it may fall down. The exhaust system becomes hot after a run. Park the vehicle in a place where pedestrians or children are not likely to touch the vehicle.

During storage, the battery must be recharged at recommended charger if stored more than a month.

**Warning**

The exhaust system becomes hot after a run. Park the vehicle in a place where pedestrians or children are not likely to touch the vehicle.

TAKING THE VEHICLE OUT OF STORAGE FOR REGULAR USE

1. Take the vehicle out of garage and clean it thoroughly.
2. Remount the battery after bench charging if required.
3. Fill the engine oil (TVS TRU4 SKUUTA - SAE 10W30 API-SL, JASO MB oil) and check the oil level using gauge oil level.
4. Fill the transmission oil (TVSTRU4 SKUUTA - SAE 10W30 API-SL, JASO MB oil) and check the oil level at the oil level screw.
5. Lubricate the parts as instructed in the periodic maintenance schedule.
6. Fill up fresh petrol in the fuel tank.
7. Check and inflate the tyres to the specified tyre pressure.
8. Check and correct the points mentioned in page No. 31.
9. Turn the ignition switch to 'ON' position. Retract the side stand if the vehicle is parked on side stand. Start the engine and ride out.



Caution

Avoid using alkaline solution like detergent soaps for washing. This may damage head lamp and other lamp assemblies.

RECOMMENDED TIPS WHEN TAKING A LONG TRIP OF MORE THAN 500 KM:

- A) Please keep the following items for use in case of emergency:
1. Tool kit complete.
 2. Recommended spark plug one number.
 3. Turn signal lamp bulb one number.
 4. Throttle, front and rear brake cable each one.
 5. First aid kit.
- B) Precautions to be taken for the journey:
1. Ensure engine oil and transmission oil are up to the level.
 2. Adequate fuel in the fuel tank.
- C) Check your scooter for the following:
1. Tightness of all bolts and nuts with correct torque value.
 2. Fitness of tyres / tyre pressure / tread depth.
 3. All bulbs, indicators and horn functioning.
 4. Smooth functioning of all cables and their free play.
 5. Smoothness of steering operation.
 6. Front / rear brake function and rear brake lamp working.

7. Front fork for any abnormality.
8. Spark plug gap and condition of spark plug.
9. Air filter element cleanliness.
10. Lubrication of all items mentioned in the periodic maintenance schedule.
11. Any other job as necessary.
12. Have your vehicle checked at any TVS Motor Company Authorised Main Dealer or Authorised Dealer.



Caution

Long journey are to be taken only after the running-in period of 1000 km.

TVS Motor Company Limited ('the Company') give this warranty with respect to the TVS Scooty Pep+ manufactured by the Company.

While the Company has taken every care to maintain quality in the manufacture of the TVS Scooty Pep+ , the above said warranty is subject to other terms of warranty:

During 5 Years from the date of purchase or during the first 50,000 km of run for the vehicle in the hands of original retail purchaser, whichever is earlier, the parts of the vehicle covered under warranty which prove to the satisfaction of the Company to have a manufacturing defect will be repaired or replaced free of cost.

The Company's obligation under this warranty is limited to repairing or replacing, free of cost, those parts of the vehicle which upon examination by the Company may prove to the Company's satisfaction to have a manufacturing defect, and in such cases the Company's decision either to repair or replace the affected parts will be final. In the event of replacement of parts, the Company also reserves the right to use parts of the same brand as the affected parts or any other brand which is used by the Company in the course of manufacture. All parts replaced under this warranty will become the property of the Company and must be returned to the company.

Limitations of Warranty:

This warranty shall not apply to following condition:

1. Any natural wear and tear, including without limitation, aging.
2. Warranty claims on proprietary items such as tyres, tubes and batteries etc., should be preferred by the user directly on the respective manufacturer, as per their warranty terms and the Company shall not be liable in any manner in respect to the same.
 - Battery warranty for "MF type (Maintenance Free)" is applicable for a period of 21 months from the date of charging or 18 months from the date of sale or 20,000 kms, whichever is earlier.
 - Battery warranty for "Lead Acid type" is applicable for a period of 15 months from date of charging or 12 months from date of sale or 10000 kms whichever is earlier.
3. Parts repaired or replaced under this warranty are warranted only throughout the remainder of the original warranty period.

4. The Company is not liable for any delay in servicing due to reasons beyond the control of the Company or any of its Authorised Main Dealers / Authorised Dealers.
5. In any event, the Company is not liable for indirect, remote, incidental or consequential damages.
6. The Company may make any modification or improvement to vehicles in future production at any time without prior notice and without any obligation to install the same on vehicles previously dispatched for sale.
7. Any claim under this warranty will lie only when the customer:
 - takes his vehicle to an Authorised Main Dealer / Authorised Dealer of the Company and reports the problem he / she felt in the vehicle to enable the Authorised Main Dealer / Authorised Dealer to inspect the same and assess the cause for the reported problems.
 - produces to such Authorised Main Dealer / Authorised Dealer the owner's manual for the concerned vehicle for verification of relevant details.
8. This is the only warranty given by the Company for the TVS Scooty Pep+. No employee, Dealer or other person is authorised to extend or enlarge this warranty.

Warning

Modifications to this vehicle not approved by the TVS Motor Company may cause loss of performance and render it unsafe for use and disqualifies for warranty coverage also.

Following Toll Free numbers can be contacted for battery related queries if any.

Incase of EXIDE battery, call :- 1800 103 5454

Incase of AMCO battery, call :- 1800 425 0096

Incase of TATA GREEN battery, call :- 1800 419 8888

Incase of AMARON battery, call :- 1800 425 5858

Following Toll Free numbers can be contacted for Tyre related queries if any.

Incase of TVS Srichakra, call :- 04522443300

Incase of JK tyre, call :- 18002581100

Incase of Maxxis tyre, call :- 1800 532 2888



List of parts not covered under warranty

| ITEM | WHAT TO CHECK FOR |
|----------------------------------|--|
| Normal Maintenance Operations | Engine tune-up, decarbonizing, fuel system cleaning, oil changes, head light focusing, fastener retightening, ignition timing, clutch and brakes as well as other normal adjustments. |
| Wear and Tear Items | Chain, sprockets, clutch and brake linings, fasteners, shims, washers, oil seals, gaskets, O' rings and spokes etc. |
| Electrical | Bulbs, fuse etc. |
| Service Maintenance Parts | Oil filters, spark plug, air filter, SAI filter, oil and brake fluid |
| Rubber, Rexine and Plastic Items | All hoses, pipes and plastic aesthetics |
| Proprietary Items | <p>Battery, tyres and tubes (the warranty terms are subject to our agreement with proprietary OEM)</p> <p>(Battery warranty for "MF type (Maintenance Free)" is applicable for a period of 21 months from the date of charging or 18 months from the date of sale or 20,000 kms, whichever is earlier).</p> <p>(Battery warranty for "Lead Acid type" is applicable for a period of 15 months from date of charging or 12 months from date of sale or 10000 kms whichever is earlier).</p> |
| Others Factors | Parts of the vehicle getting affected due to atmospheric effect / environmental factors (rusting, paint peel off etc.). However, depending on the vehicle usage condition, warranty would be accepted up to 2 years from the date of purchase. |
| | Parts of the vehicle which have been tampered with, altered, repaired or replaced by persons not authorised by the Company and which in the sole judgement of the Company affect the performance of the vehicle. |

List of parts not covered under warranty

| ITEM | WHAT TO CHECK FOR |
|----------------|---|
| Others Factors | Parts which are used in conjunction with parts not made or recommended by the Company. |
| | Parts suffering damage or resultant damage by accident, misuse, negligent treatment, use of bad quality lubricants or impure fuel or by omission to follow the guidance and instructions contained in this owner's manual. |
| | Vehicles on which engine number or chassis number is deleted, defaced or altered. |
| | Vehicles on which any warranty service including scheduled paid service is not availed when it falls due (at TVS Motor Company Authorised Main Dealer / Authorised Dealer). |
| | <p>Vehicles sold or transferred by original retail purchaser.</p> <p>Vehicles used for racing or any competition or used otherwise than for ordinary personal transportation.</p> <p>Vehicles attached with side cars etc.</p> <p>Vehicles which have been taken out of India.</p> <p>Vehicles affected by natural calamities like flood, earthquake, tsunami, storm etc.,.</p> |
| | If the vehicle has been used for commercial purpose like taxi or used for rental or hiring or any other purpose other than regular personal transportation. |

SERVICE INFORMATION

There are seventeen services for TVS Scooty Pep+ during warranty period. Of these, first four services are free services for which labour charges are free. In addition to these four free services, we have a scheme of thirteen pay services. For keeping the maintenance track of your vehicle, free and pay service record sheets are attached with the Service Handbook. Please have the record sheets filled by the Dealer who is carrying out the maintenance service.

For availing any of the seventeen warranty services, please take your vehicle and your Service Handbook to any of our Authorised Main Dealers or any of our Authorised Dealer. After effecting the service the Authorised Main Dealer or the Authorised Dealer will affix their stamp on the last column of the free or pay service record sheet for your record and reference. An OTP would be sent to customer's registered mobile number. The same to be shared with the servicing Dealer on or before vehicle delivery.

Periodic maintenance always helps good performance of an automobile and our services are planned to keep your TVS Scooty Pep+ performing good. **Please note that carrying out the service for your vehicle at scheduled intervals at any of the TVS Motor Company Authorised Main Dealer / Authorised dealer is necessary for availing of warranty.** And please also remember that, after the services are over, periodic servicing of your vehicle at appropriate intervals, depending upon its extent of use, will keep your vehicle at its best level of performance.

In case you need any clarification or assistance, please feel free to write to us mentioning the frame number, engine number and date of purchase of your vehicle also the name and place of the Authorised Main Dealer / Authorised Dealer from whom you bought the vehicle and getting it serviced.

Service Department

TVS MOTOR COMPANY LIMITED

P.O. Box No. 4, Harita, Hosur - 635 109,

TAMILNADU, INDIA.

Toll free no:- 1800-258-7111

Planned Service Schedule (kms or month whichever of the two occurs early)*

| Sl.No. | Service | Type | Kms | Months |
|--------|--------------|------|---------------|--------|
| 1 | 1st Service | Free | 500 ~ 750 | 2 |
| 2 | 2nd Service | | 2500 ~ 3000 | 4 |
| 3 | 3rd Service | | 5000 ~ 6000 | 8 |
| 4 | 4th Service | | 8500 ~ 9000 | 12 |
| 5 | 5th Service | Pay | 11500 ~ 12000 | 16 |
| 6 | 6th Service | | 14500 ~ 15000 | 20 |
| 7 | 7th Service | | 17500 ~ 18000 | 24 |
| 8 | 8th Service | | 20500 ~ 21000 | 28 |
| 9 | 9th Service | | 23500 ~ 24000 | 32 |
| 10 | 10th Service | | 26500 ~ 27000 | 36 |
| 11 | 11th Service | | 29500 ~ 30000 | 40 |

| Sl.No. | Service | Type | Kms | Months |
|--------|--------------|------|---------------|--------|
| 12 | 12th Service | Pay | 32500 ~ 33000 | 44 |
| 13 | 13th Service | | 35500 ~ 36000 | 48 |
| 14 | 14th Service | | 38500 ~ 39000 | 51 |
| 15 | 15th Service | | 41500 ~ 42000 | 54 |
| 16 | 16th Service | | 44500 ~ 45000 | 57 |
| 17 | 17th Service | | 47500 ~ 48000 | 60 |

i Note

Free service enables the customer to avail the service at free of labour charges. Charges for the pay service should be borne by the customer. Cost of engine oil, periodic maintenance parts, filter, brake fluids, all types of greases, petroleum jelly, distilled water, chain cleaner, lubricants, coolants, cleaning cloths for both free and paid services are chargeable to the customer.

** Please remember that, after the above schedule, periodic servicing of your vehicle at appropriate intervals, depending upon its extent of use, will keep your vehicle at its best level of performance.*

| DESCRIPTION | TVS Scooty Pep+ |
|----------------------|--|
| MANUFACTURER | TVS Motor Company Limited P.B. No. 1, Bythahalli, Kadakola post, Mysore - 571 311, India |
| ENGINE | |
| Type | Single cylinder, 4 stroke, fuel injection, air cooled, spark ignition engine |
| Cylinder bore | 51 mm |
| Stroke | 43 mm |
| Piston displacement | 87.8 cc |
| Compression ratio | 10.1 : 1 |
| Air filter | Polyurethane foam filter element |
| Oil filter | Wire mesh |
| Lubrication system | Forced wet sump |
| Maximum power in kW | 4.0 kW @ 6500 rpm |
| Maximum torque in Nm | 6.5 Nm @ 3500 rpm |
| Maximum speed | 66 km/h |
| Engine idling rpm | 1500 ± 100 rpm (under warm condition) |
| Starting system | Electric starter / Kick starter |
| Emission norms | BS VI |



| DESCRIPTION | TVS Scooty Pep+ |
|--|--|
| TRANSMISSION | |
| Clutch | Dry - Centrifugal clutch |
| Primary transmission | CVT (Continuous Variomatic Transmission) |
| Primary reduction | 2.50 to 0.9 |
| Secondary reduction | 10.47 |
| CHASSIS | |
| Overall length | 1735 mm |
| Overall width | 660 mm |
| Overall height | 1065 mm |
| Ground clearance (unladen) | 135 mm |
| Wheel base | 1230 mm |
| Kerb weight (with toolkit and 90% of fuel) | 93 kg |
| Pay load | 130 kg |
| Maximum laden weight | 223 kg |
| Steering angle | 86° |
| Caster angle | 25° |
| Frame | Duplex tubular frame |
| Front suspension | Aluminum telescopic, hydraulic, dual rated |
| Rear suspension | Toggle link, hydraulic damper with triple rated spring |
| Trail length | 90 mm |

| DESCRIPTION | TVS Scooty Pep+ |
|------------------------------|----------------------------------|
| BRAKES | |
| Front (Drum) | 110 mm dia (hand operated) |
| Rear (Drum) | 110 mm dia (hand operated) |
| TYRE | |
| Front tyre | 3.00-10 4PR 42J |
| Rear tyre | 3.00-10 4PR 42J |
| Front tyre pressure** | 1.69 kg/cm ² (24 PSI) |
| Rear tyre pressure - Solo** | 2.04 kg/cm ² (29 PSI) |
| Rear tyre pressure - Dual** | 2.50 kg/cm ² (36 PSI) |
| ELECTRICAL | |
| Ignition system | ECU controlled ignition |
| Spark plug | BOSCH UR5KCW / CHAMPION RG8MC4 |
| Spark plug gap | 0.9 ~ 1.0 mm / 1.0 ~ 1.1 mm |
| Battery type | 12V, 5Ah Lead Acid |
| Generator (flywheel magneto) | 12V, 135 W |
| Head lamp | 12V, 35/35W x 1 |
| DRL | 12V, LED |
| Tail / brake lamp | 12V, 5/21W x 1 |

** In cold condition

| DESCRIPTION | TVS Scooty Pep+ |
|----------------------------------|-----------------------------|
| ELECTRICAL | |
| Turn signal lamps bulb | 12V, 10W x 4 |
| Number plate lamp bulb | 12V, 4W x 1 |
| Speedometer lamp bulb | 12V, 1.7W x 2 |
| Turn signal indicator lamp bulb | 12V, 1.7W x 1 |
| High beam indicator lamp bulb | 12V, 1.7W x 1 |
| Economy mode indicator lamp bulb | 12V, 1.7W x 1 |
| Side stand indicator lamp | 12V, 1.7W x 1 |
| Malfunction indicator lamp | 12V, LED |
| Horn | 12V, DC |
| Fuse (blade type) | 12V, 15A x 1 & 12V, 10A x 1 |

 **Caution**

Using the bulb other than the specified rating can result in overloading of the electrical system or premature failure of the bulb.

| DESCRIPTION | TVS Scooty Pep+ |
|----------------------------------|--|
| CAPACITIES | |
| Fuel tank capacity ^{**} | 4.2 l |
| Fuel | BS VI petrol with minimum RON 91 (containing upto 10% of ethanol by volume) |
| Engine/transmission oil grade | TVS TRU4 SKUUTA oil (SAE 10W30 API-SL, JASO MB) |
| Engine oil capacity | 750 ~ 800 ml (during regular service) 800 ml (incase of disassembly) |
| Transmission oil capacity | 100 ml (during regular service) 120 ml (incase of disassembly) |
| Front fork oil grade | IOC / Castrol - Gabriel Premium front fork oil |
| Front fork oil capacity | 53 ± 1 ml per leg |

i Note

Specifications are subject to change without notice.

^{**} The fuel tank is not a measuring instrument and the capacity of the fuel tank may vary from the indicated capacity

GENERAL INFORMATION



Dear Customer,

It is mandatory under the Motor Vehicles Act to insure all motor vehicles. No motor vehicle can be used in a public place without a valid policy of insurance issued by an authorised insurer. Driving a motor vehicle without any such insurance is an offense under Motor Vehicles Act.

To assist our Customers on their insurance requirements such as the prompt issue and renewal of policies as well as expeditious settlement of claims if any, our preferred insurers are:





ALWAYS USE TVS-M GENUINE PARTS



TVS Motor Company Limited. P.B. No.4, Harita, Hosur - 635109, Tamil Nadu, India, Telephone: +91(4344)276780
FAX: +91 (4344)277311/276878 | www.facebook.com/scootygirls | www.tvsscooty.com | www.tvsmotor.com